

# GSM Mobile Phone Based LED Scrolling Message Display System

Prachee U.Ketkar<sup>1</sup>, Kunal P.Tayade<sup>2</sup>, Akash P. Kulkarni<sup>3</sup>, Rajkishor M.Tugnayat<sup>4</sup>

Department of Information Technology

Jawaharlal Darda Institute Of Engineering & Technology, Yavatmal, Maharashtra, India

Prachee.ketkar23@gmail.com

**Abstract-**In the last couple of decades, communication technology has developed by leaps and bounds. The use of “Embedded System in Communication” has given rise to many interesting applications. One of such applications is public addressing system (PAS). Many companies are manufacturing audio / video systems like public announcement system, CCTV, programmable sign boards etc. But all these systems are generally hard-wired, complex in nature and difficult to expand. So, by adding wireless communication interface such as GSM to these systems, we can overcome their limitations . Now-a-days LED Message Scrolling Displays are becoming very popular .These displays are used in shopping malls, theaters, public transportation, traffic signs, highways signs, etc. This paper describes the GSM based LED display.

**Keywords-**GSM, Interface, Message, Modem, Receiver, Transmitter,

## I Introduction

Over the last few years, the GSM cellular phone has grown from a luxury item owned by the rich to something so common that one out of five Filipinos already owns one. This is amazing when we look at the fact that our country is a developing one with almost half our population living below the poverty line. This continuously growing popularity of the GSM cell phone has spurred the growth of the country’s cellular network infrastructure led by the two major players, Ayala owned Globe Telecom, and PLDT’s Smart Cellular.[3] All major urban areas are currently covered by both cellular providers, and soon every single corner of the Philippine Archipelago is a cell phone call away. The primary reason we can see for this tremendous and unexpected cellular boom is the popularity of the short message service (SMS) in the Philippines. Locally called “text messaging,” Filipinos send more text messages than the whole of Europe combined. The Filipino’s need for constant communication with family and friends, coupled with the relatively cheap method of sending short text messages to them, has spurred a GSM revolution in the country. In fact, rarely will a Filipino actually use his cell

phone to make a phone call, preferring to “text” anything and everything. The “texting” boom has not come unnoticed to entrepreneurs. A variety of services have grown around “texting.” Users will pay double or quadruple the normal SMS fee for a specific service such as chatting, news/traffic reports, and downloading of ring tones for their phones. These services ally themselves with one or more cellular network providers who will give them a special phone number that can receive and monitor the text messages that their customers send to them. This many-to-one network of SMS transmission has become quite popular and many a business has entered into this model with mixed results. However, as of this writing, the vast majority of businesses that revolve around the GSM-SMS system have been targeted to consumers. This paper aims to propose industrial applications that will utilize the distinct advantages of the GSM.SMS system over other possible technologies in the industrial setting. [2]

### A. GSM for Industrial Applications

The primary appeal of the GSM network for industrial applications are in its following qualities:

**1.Digital Transmission-** The GSM Network is inherently digital which makes it secure, relatively error-free, and jamming-proof.[2]

**2.Nationwide coverage-** The GSM networks offer nationwide access at a fixed fee regardless of location.

**3Future-proof-**The GSM network is designed to be compatible with future technology upgrades such as GPRS and third generation (3G) cellular telephony. Thus, investments in this area are relatively safe in the medium to long term.[3]

**4.Cheap-**GSM technology in terms of hardware and fees paid to providers will get cheaper as it grows more popular and as the technology matures.

**5.Mobile-** GSM technology allows for a roaming system, wherein both transmitter and receiver can be move around the cellular network. There are a variety of applications wherein the GSM network can be useful for industrial use, and most of these are in the realm of Data Transmission.

This can be in the form of: telemetry systems, remote access and control systems, remote display systems and others. Being inherently digital, sending digital data with the GSM network is very simple and easy. Information transmission through the GSM network can be in the form of:

**Voice Channel Transmission-** Much like how a regular fixed line modem works, data can be transmitted to the cell phone's voice channel at speeds comparable to a fixed line modem.

**GPRS transmission-** The "2.5 G" GPRS technology that is slowly gaining popularity in the Philippines allows for high-speed data transmission for the newest cell phone models.

**SMS transmission-** Using a 160- character text message, short commands can be sent via SMS and decoded by a receiver. This is ideal for intermittent small packet data transmission.[1]

## II. Analysis Of Problem

Now a day's every advertisement is going to be digital. The big shops and shopping centers are using the digital moving displays now. In Railway station and bus stands everything that is ticket information, platform number etc is displaying in digital moving display. But in these displays if they want to change the message or style they have to go there and connect the display to PC or LAPTOP. Suppose the same message if the person want to display in main centers of the cities ,means he has to go there with laptop and change the message by connecting into PC .This system is also useful mainly for police or army .i.e. displays will be connected to all the main centers in city if they want to display messages about something crucial within 5 minute, which they cannot. So keeping this in mind a new display system which can be accessed remotely, using the GSM technology to make the communication between microcontroller and mobile was designed.

## III.Design overview

The led Display System is aimed at the colleges and universities for displaying day-to-day information continuously or at regular intervals during the working hours. Being GSM-based system, it offers flexibility to display flash news or announcements faster than the programmable system.[4] GSM-based display system can also be used at other public places like schools, hospitals, railway stations, gardens etc. without affecting the surrounding environment. The led display system mainly consists of a GSM receiver and a display toolkit which can be programmed from an authorized mobile phone. It receives the SMS, validates the sending Mobile Identification Number (MIN) and displays the desired information after necessary code conversion.[9] It can serve

as an electronic notice board and display the important notices instantaneously thus avoiding the latency. Being wireless, the GSM based led display is easy to expand and allows the user to add more display units at anytime and at any location in the campus depending on the requirement of the institute. [9]

A text message is typed in the GSM mobile phone and sent it by using SMS service of the mobile phone to LED moving display boards. A GSM modem is connected to the LED display hardware is used to receive the SMS and send it to the controller circuit of the LED display. Then the controller circuit of the LED display filters the message content in SMS and changes the display text in LED display dynamically. [4]By using this SMS service it is possible to change the text in the LED display board from anywhere in the country. The idea described in this paper reduces the total cost that is required in the traditional LED display boards not only it makes easier to send message to the LED display boards. The system uses a GSM modem at the display side to receive SMS. An IC AT89c51 belongs to microcontroller act as controller to drive the LED display board. Along with these a power supply unit and supporting hardware for microcontroller is used.

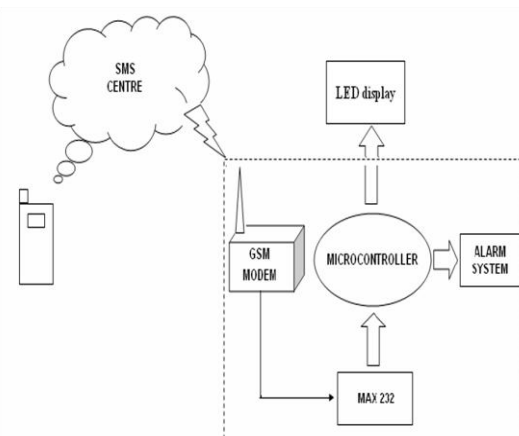

Figure 1 . Design overview of GSM mobile phone based LED scrolling message display system.

## IV. Proposed Work

This will be a moving message display, which can be used as the digital notice board, and also a GSM modem, which is the latest technology used for communication between the mobile and the embedded devices. System will work like when the user wants to display or update the notice board, the user has to send the message from his mobile defining the message and then the password of the system to the number of the SIM which is inserted in the display system MODEM. Then the MODEM connected to the display system will receive the SMS, the microcontroller inside the system is programmed in such a way that when the modem

receives any message the microcontroller will read the message form serial port and verify for the password, if the pass word is correct then it will start displaying the messages in the display system. The messages are displayed on the LED display. The prototype of the GSM based display toolkit has facilities to be integrated with a display board thus making it truly mobile. The toolkit accepts the SMS, stores it, validates it and then displays it in the led module. The SMS is deleted from the SIM each time it is read, thus making room for the next SMS. The major constraints incorporated are the use of '\*' as the termination character of the SMS and the display of one SMS as a time. The limitations can be removed by the use of higher end microcontrollers and extended RAM. The prototype can be implemented using commercial display boards. The use of "Embedded System in Communication" has given rise to many interesting applications that ensures comfort and safety to human life. GSM technology is one of the new technologies in the embedded field to make the communication between microcontroller and mobile. Now every embedded system is used to communicate with other system using GSM and GPRS technology, In this system the MODEM is used to access the message sent by the user to display on notice board. This system has many important applications and can be used to update the remote notice board from far off places using GSM MODEM by sending SMS between the mobile and the embedded devices (microcontroller 89c51). This remote control of notice board is possible through embedded system. The microcontroller is interfaced with GSM Modem in mobile phone via MAX232 level convertor. The microcontroller system is designed to allow easy use of a mobile phone to update the notice board at any far location. Using a mobile phone the development of the notice board is being carried out using SMS, this will update the notice board with the help of the microcontroller modules attached to it, which provides the moving message displayed on the LED using 89c51.

**Background Study-**SMS application has been used in education to send notification using paperless environment to a group of students in campus pertaining to class cancellation, test announcement and class postponements without pasting information using paper. The advantages of the work includes that the information could be received quickly and it reduces the number of non-notified students. This presents a new way of online communications through mobile to notice board that helps students and lecturers to be always aware of appointments no matter where they are. Among the advantages of the system include reduced time lag problem.

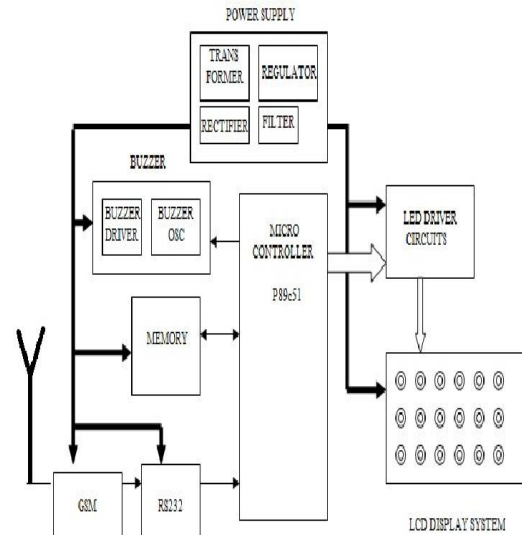

Figure 2. Receiver circuit

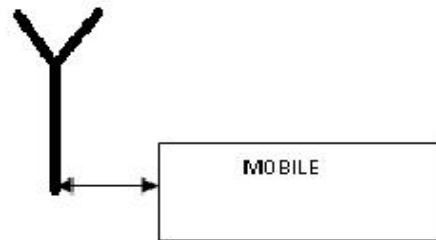

Figure 3. Transmitter

**A. Description Of Block Diagram-**

**1.Power supply:** Power Supply is an important part of a circuit. It provides required supply to different blocks of the circuit from input 230 V AC. The main blocks include transformer, rectifier circuit, filter circuit, and regulator circuit. Voltage regulator IC LM7805 is used as a voltage regulator.[8]

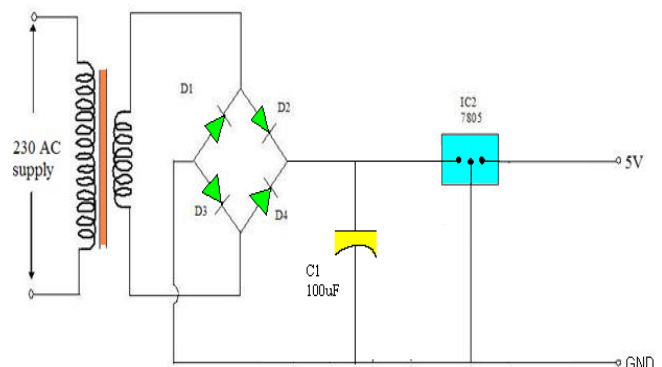

Figure 4. Block Diagram of Power Supply

The microcontroller and other devices get power supply from AC to DC adapter through 7805, 5 volts regulator. The adapter output voltage will be 12V DC non regulated. The 7805/7812 voltage regulators are used to convert 12 V to 5V/12V DC.

**2. Micro controller - AT89C51**

8051 based CMOS controller with dual DPTR, 32 I/O Lines, WDT, PCA, 3 Timers/Counters, 7 Interrupts/4 Priority Levels, 64K Bytes ISP FLASH EPROM, 256 Bytes on-chip RAM.[7]

Vital role of micro controller in ‘Remote notice board using GSM with SMS:

The microcontroller inside the system is programmed in such a way that when the modem receives any message, the microcontroller will read the message form serial port and verify for the password, if the pass word is correct then it will start displaying the messages on the LED display system. LED is connected to microcontroller as 4 bit data mode, before displaying anything on the LED, initialization has to be done ,so microcontroller will control the LED initialization and select the data register and command register according to the purpose .Memory is connected to microcontroller using two pins, it is communicating with the microcontroller through I2C communication.[7],[8]

**3. Buzzer:**

Buzzer is controlled by the microcontroller using single pin. Sometimes it can be interchanged according to the transistor used to drive the device. The buzzer subsystem produces a 2 KHz audible tone when powered. The buzzer will sound when the signal coming into the driver is high. It must be connected to a Darlington transistor\_ or transducer driver subsystem .The buzzer is connected between the supply rail (+ V) and the input signal.[7] This acts as load on the driver. When the input signal coming into the buzzer subsystem is low, a potential difference across the buzzer causes current to flow. It is this flow of current that causes the buzzer to sound. Buzzer is connected to microcontroller port pin, so microcontroller will give high or low to switch on/off buzzer. In this system it is used to define the arrival of the SMS in the form of sound.[7],[8]

**4. RS232 converter (MAX 232N):**

Vital role of RS232 converter (Max 232n) in „GSM based LED display“. RS232converter is a chip to convert the TTL voltage levels into RS232 level and vice versa. In this system GSM modem is communicated with the microcontroller using RS232serial data format. In order to make MODEM serial port compatible with microcontroller serial port the RS232 converter is used.[8]

**5. External EEPROM memory (2 Kbytes):**

These memory devices are used to store the data for off line process. The AT24C02provides 2048 bits of serial electrically erasable and programmable read only memory(EEPROM) organized as 8192 words of 8 bits each. The device is optimized for use in many industrial and commercial applications where low power and low voltage

operation are essential. EEPROM is communicating with the microcontroller using I2C communication i.e. it contains one data pin and clock pin, these device are connected as slave to the microcontroller. The main application of memory in this system is to store the message coming from user mobile, when the microcontroller is doing the operation of writing and reading to memory.[8]

**6. GSM modem (900/1800 MHz):**

A GSM modem is a wireless modem that works with a GSM wireless network. A wireless modem behaves like a dial-up modem. The main difference between them is that a dial-up modem sends and receives data through a fixed telephone line while a wireless modem sends and receives data through radio waves.[5] Like a GSM mobile phone, a GSM modem requires a SIM card from a wireless carrier in order to operate. Generally, computers use AT commands to control modems. Reading of message from the SIM card inserted into the modem is done by sending the appropriate AT command to the modem. In addition to the standard AT commands, GSM modems support an extended set of AT commands. These extended AT commands are defined in the GSM standards. [6]Some common basic SMS related AT Commands are shown in table below:

AT Command	Meaning
+CMGS	SEND MESSAGE
+CMSS	SEND MESSAGE FROM STORAGE
+CMGW	WRITE MESSAGE TO MEMORY
+CMGD	DELETE MESSAGE
+CMGC	SEND COMMAND
+CMSS	MORE MESSAGES TO SEND

Figure 5. AT Commands

**B. Description Of The Interfaces:**

- The modem comprises several interfaces:
- LED Function including operating Status
- External antenna ( via SMA)
- Serial and control link
- Power Supply (Via 2 pin Phoenix contact )
- SIM card holder

**C. Hardware required:**

- The hardware board contains microcontroller AT89c51 which is the heart of the system.
- A wireless GSM MODEM.
- LED display
- Max 232

- Memory (EEPROM)
- Power supply

#### D. Software required:

- **Express PCB**-Express PCB is free PCB software and is a snap to learn and use. Designing circuit boards is simple for the beginner and efficient for the professional. The board manufacturing service makes top quality two and four layer PCBs.
- **Embedded C**-Embedded C is used for microcontroller programming. There is a large and growing – international demand for programmers with 'embedded' skills, and many desktop developers are starting to move into this important area. Because most embedded projects have severe cost constraints, they tend to use low-cost processors like the 8051 family of devices considered in this paper.
- **Keil**-Keil development tools for the 8051 Microcontroller Architecture support every level of software developer from the professional applications engineer to the student just learning about embedded software development. The Keil 8051 Development Tools are designed to solve the complex problems facing embedded software developers.
- **Visual Basic**-Visual Basic (VB) is an event driven programming language and associated development environment from Microsoft for its COM programming model. Visual Basic was derived from BASIC and enables the rapid application development (RAD) of graphical user interface (GUI) applications. Visual Basic allows many additional components to be added to the toolbox. The Microsoft component is used to add a serial communication facility. Here we have used VB also for providing graphical user interface at PC for easy access to display system, password changing and monitoring.

#### E. GSM MODEM-PC Interfacing

GSM Modem is used to receive message from the authorized user. This GSM modem requires a SIM card from a wireless carrier in order to operate. This SIM number is contact number of the receiving section. [5],[6] PCs use AT commands to control modems. Although GSM modem is interfaced with PC through Bluetooth using a VB program, a GSM modem can be tested before actually implementing into the system. The MS HyperTerminal is a handy tool when it comes to testing the GSM device.

It can be found at *Start -> Programs -> Accessories -> Communications -> HyperTerminal*. Various parameters like connection name, icon, comm port, and correct port settings are specified for our GSM modem. Finally in the hyper terminal main window,

AT commands are sent and responds received from GSM modem can be seen. Screenshot of dialog box showing sending and receiving of AT commands is shown in figure below (Here mobile phone connection is the connection name)

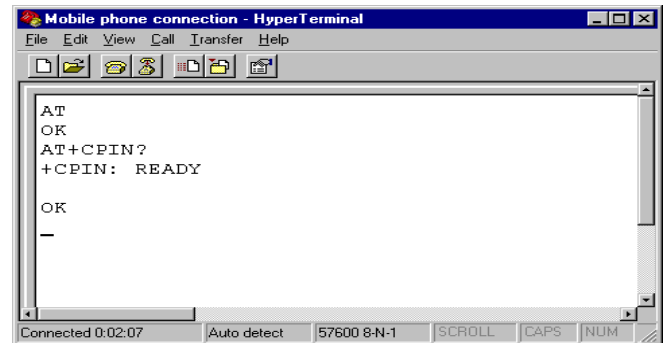

Fig 6. The screenshot of MS HyperTerminal's main window in Windows 98.

We will first have to type "AT" A response "OK" should be returned from the mobile phone or GSM modem. Now we will type "AT+CPIN?". The AT command "AT+CPIN?" is used to query whether the mobile phone or GSM modem is waiting for a PIN (personal identification number, i.e. password). If the response is "+CPIN: READY", it means the SIM card is ready for use. After this, various AT commands depending on the used modem's instruction set are send to modem and responses are received. This process is very useful in testing GSM modems.

#### V. Features Of LED Display

Microcontrolled based scrolling message display has the following features:

- 1.The message to be displayed is stored in memory and the message length to be displayed is limited only by free memory space of the microcontroller.
- 2.The number of character displayed at a time can be high as 30.
- 3.The running speed of the message can be increased or decreased by pressing switches. Here, the circuit is designed for displaying English character on a 35LED dot matrix display. Microcontroller port is used to display code and clock signal for the scrolling message display. Parallel-input parallel output registers are used to shift the signal from right to left. The clock pulse and code signal are generated by microcontroller program and output from the port. Theoretically, we can add infinite number of PIPO registers but the maximum number of registers is actually limited to the current triggering value of the clock pulse. To add a large number of PIPO registers, amplify the clock pulse prior to connecting it to the PIPO IC'S

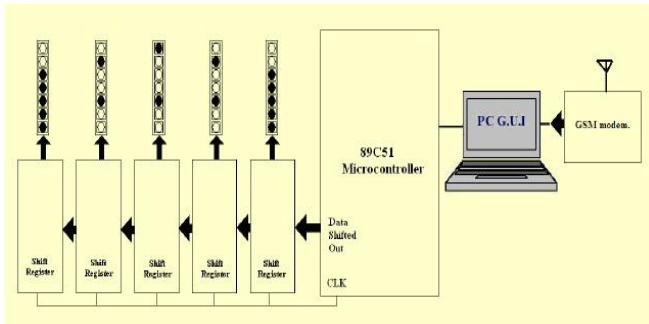

Figure 7. Block diagram for one character

The above diagram displays the Block Diagram of the system for one character. As shown in diagram data is shifted out from the microcontroller and given to the shift register. When clock is given to the shift register it displays the data to LED and provides input to next shift register and the process goes on. The above block diagram is for single character and there are many such characters in system. The microcontroller is connected with GSM modem which is used to receive any message and that particular message will be displayed on the LED matrix display. Other special characters can be added as follows. Suppose you want to display character 'A'. draw 'A' on the 5x7 LED display.

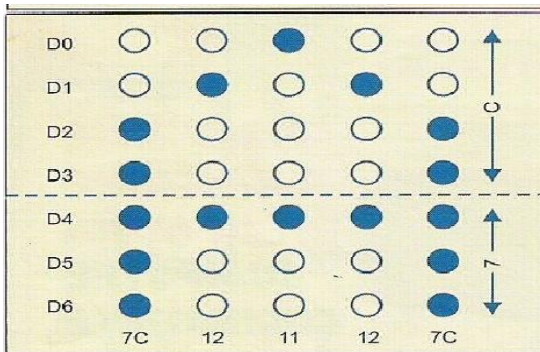

Figure 8. Character 'A' on the 5x7 LED display

Suppose you want to display special character '<' on the 5 X 7display.

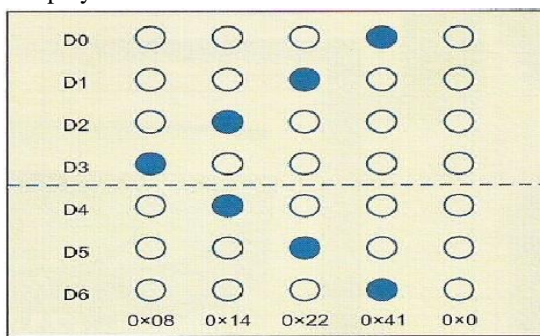

Figure 9. Special character '<' on the 5 X 7display.

## VI. Applications

- Colleges: for displaying important messages . eg : placement news, cultural activities news ,etc.[4]
- Hotels : to display the availability of the rooms and the room rents , the type of rooms.[3]

- Restaurants :to display the menu and offers etc.
- Railway stations : to display the scheduling time of the train and the platform, the services offered by the railways .
- Nursing homes : to display the staff attendance ,the availability of the doctors, the list of the specialized doctors, no of in patients etc.[4]

## VII. Future Enhancement

- A commercial model can be able to display more than one message at a time.
- In our system we are sending messages via GSM network and displaying on a LED by utilizing AT commands. The same principle can be applied to control electrical appliances at a distant location.
- Robots can be controlled in a similar fashion by sending the commands to the robots. This can be used for spy robots at distant locations, utilized by the military to monitor movement of enemy troops.

## VIII. Conclusion

By introducing the concept of wireless technology in the field of communication we can make our communication more efficient and faster, with greater efficiency we can display the messages and with less errors and maintenance. This model can be used very efficiently in establishments like chain restaurants wherein the order and special discounts can be displayed at all branches simultaneously, in colleges wherein students and staffs can be informed simultaneously in no time. It can be set up at public transport places like railways, bus station, and airport and also at roadside for traffic control and in emergency situations, it is cost efficient system and very easy to handle. Latency involved in using of papers in displaying of notices is avoided and the information can be updated by the authorized persons.

## IX. References

- I. Gao , W., Zhang, G. and Jiang, X. "Study Implementation of Agricultural SMS Management System". In Proceedings of IEEE International Conference on Information Technology and Computer Science, 13-17 October 2009, Beijing, China, pp. 1-4, 2009.
- II. Shereen , N. Z. and Rozumah , B. "Mobile Phone use Amongst Student in University in Malaysia: It correlates and relationship to Psychological Health". European Journal of Scientific Research. Vol. 37. No.2. pp. 206 – 218, 2009
- III. Bollen, L., Eimler, S. and Hoppe, H.U. "SMS-based Discussions – Technology Enhanced Collaboration for a

- Literature Course". In Proceedings of the 2nd IEEE International Workshop on Wireless and Mobile Technologies in Education, 24- 27 May 2004, Germany, pp. 1-2, 2004
- IV. Deng chunjjan, Liu Wei, Zou Kun, Yang Liang "A Solution Of LED Large Screen Display Based On Wireless Communication",10.1109/apwcs.2010.24
- V. Books: GSM and Personal Communicati - ons Handbook- SiegmundRedl - MatthiasWeber- MalcolmW. Oliphant
- VI. Books: Principles and Applications of GSM - Vijay Garg
- VII. Sedra and Smith, Microelectronic Circuits, *fourth edition*, Oxford University Press, 1998
- VIII. R.S. Sedha, 2002. A Text Book of Applied Electronics, S. Chand and Company Ltd., New Delhi
- IX. Theodore S. Rappaport, Wireless Communications, *second edition*, PHI. New Delhi